

Ref. Part
No. No. Description

Agitator 48416036 - 18"

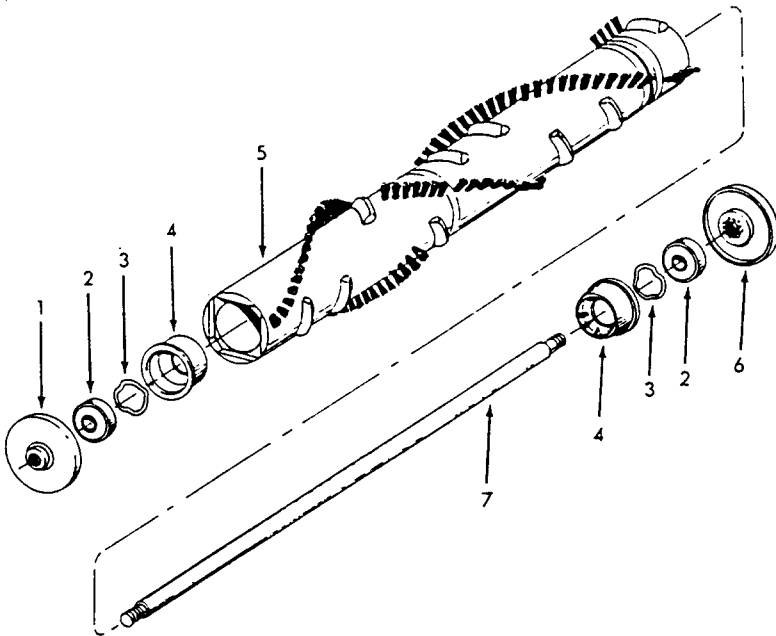

1	41435066	Thread Guard
2	24152807	Bearing
3	21345113	* Wave Spring Washer
4	36422004	AgitatorEnd
5	48416017	Agitator Body w/Ends
6	41435061	Thread Guard
7	32873004	Agitator Shaft

Ref. Part
No. No. Description

Agitator 48416035 - 14"

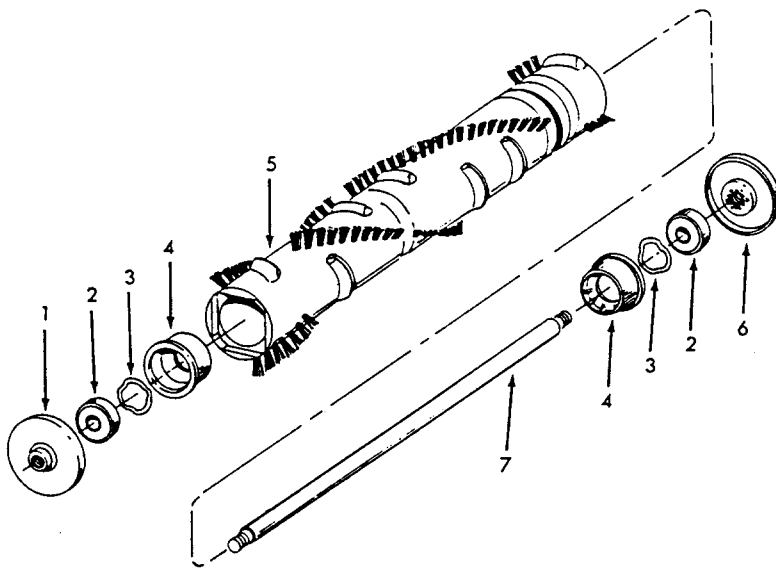

1	41435066	Thread Guard
2	24152807	Bearing
3	21345113	* Wave Spring Washer
4	36422004	AgitatorEnd
5	48416013	Agitator Body w/Ends
6	41435061	Thread Guard
7	32873007	Agitator Shaft

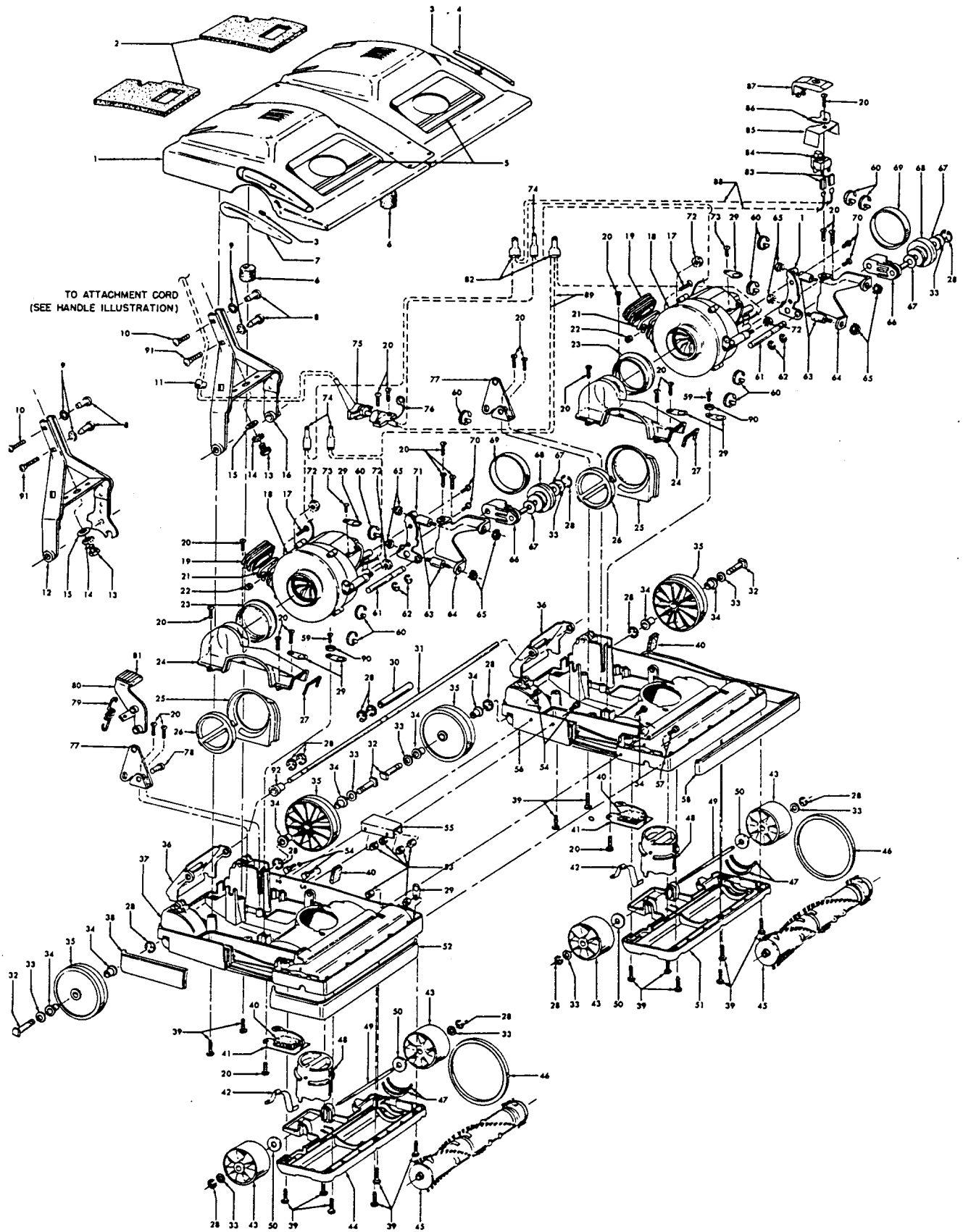

Twin Conquest Cleaner

Model C1119

Ref. No.	Part No.	Description
1	42251329	Twin Hood Assm. - LA
2	38783005	Gasket (2)
3	21364102	+ Speed Nut (2)
4	36222012	Wear Strip-L.H.
5	52115108	Nameplate (2)
6	31164004	Motor Cushion (2)
7	36222017	Wear Strip - R.H.
8	32277021	Handle Nut - AW/AY (4)
9	13704	* Washer- Lock - Special (4)
10	21631302	Bolt - AW (2)
11	36172015	Cord Retainer HP
12	41416081	Bail - AX
13	21811027	Bolt (2)
14	21356014	+* Lockwasher (2)
15	21312799	* Washer (2)
16	41416082	Bail AX
17	21765140	+ Machine Screw (2)
18	43574116	Motor Assm. (2)
19	38671008	Bellows (2)
20	21447003	* Screw (2)
21	34797008	Clamp Band - AY (2)
22	15854EF	* Hex Nut (2)
23	38671005	Duct Boot (2)
24	38657020	Air Duct- BZ (2)
25	41119008	Cap Lock- LY (2)
26	37257074	Cap- AG (2)
27	34253013	Duct Gasket (2)
28	160017	* Retaining Ring (14)
29	45517	* Lead Wire Holder (7)
30	31744025	Spacer
31	32543014	Bail Shaft
32	32512001	Rear Axle (4)
33	163110	* Washer
34	162143	Bearing (8)
35	38522036	Rear Wheel (4)
36	42256106	Exhaust Flange (2)
37	37241120	Main Body - R.H.
38	36231084	Furniture Guard - AG - Short
39	21447012	* Screw - Self Tapping (1 6)
40	34141005	Motor Cushion (4)
41	35121001	Access Door (2)
42	38381005	Spring (2)
43	38522034	Front Wheel (4)
44	37245096	Bottom Plate- R.H.
45	48416035	Agitator Assm. (2)
46	38528013	'V' Belt (2)
47	38781008	Gasket (2)
48	36436005	Height Adjustment Cap (2)
49	32543005	Front Axle (2)
50	21312754	* Washer- EF (4)
51	37245095	Bottom Plate - L.H.
52	41211030	Furniture Guard-LY

Ref. No.	Part No.	Description
53	1107602	Hex Lock Nut- Special (6)
54	21781154	+ Hex Head Machine Screw (5)
55	34612002	+ Bracket - AY
56	37241119	Main Body-L.H.
57	49417AZ	+* Pan Head Machine Screw
58	41211029	Furniture Guard - LY
59	166648AW	+* Screw (2)
60	27479307	* Lead Wire Tie (1 0)
61	31534001	Shaft (2)
62	13730	* Lock Ring (4)
63	32724010	Sandwich Mount (4)
64	36321006	Motor Support Bracket
65	21852158	Nut (8)
66	43256007	Pulley Shaft & Support Arm (2)
67	31158008	Bearing (4)
68	43256002	Pulley (2)
69	38528036	Belt (2)
70	17001FW	Screw (4)
71	36321002	Mounting Bracket
72	21652005	* Hex Nut - EF (4)
73	17001FW	Screw (2)
74	12227	Insulated Terminal (3)
75	36216008	Cord Protector
76	27478611	+ Cable Wedge
77	35214009	Foot Lever Support
78	32215002	Shaft
79	38335008	Spring
80	43151006	Handle Control Lever Assm.
81	38426030	Foot Pad
82	18972	Insulated Terminal (2)
83	162961	Insulating Pod (2)
84	28212009	Push Switch
85	68182547	* Switch Protector
86	36171030	Clamp Push Switch
87	38426047	Switch Pedal - HP
88	46183032	+ Lead Wire - Black
89	46311044	Cord - Stripped
90	15854EF	* Nut - Special
91	21831024	Bolt (2)
92	32172010	Bushing

PACKAGING MATERIAL

58186026	+ Cleaner Carton
58333011	+ Bottom Support
58347009	+ Top Support
58353010	Dust Cup Support
58433005	Tube
56711073	+ Operating Instructions
56711072	+ Assm. Instructions

Motor 43574116

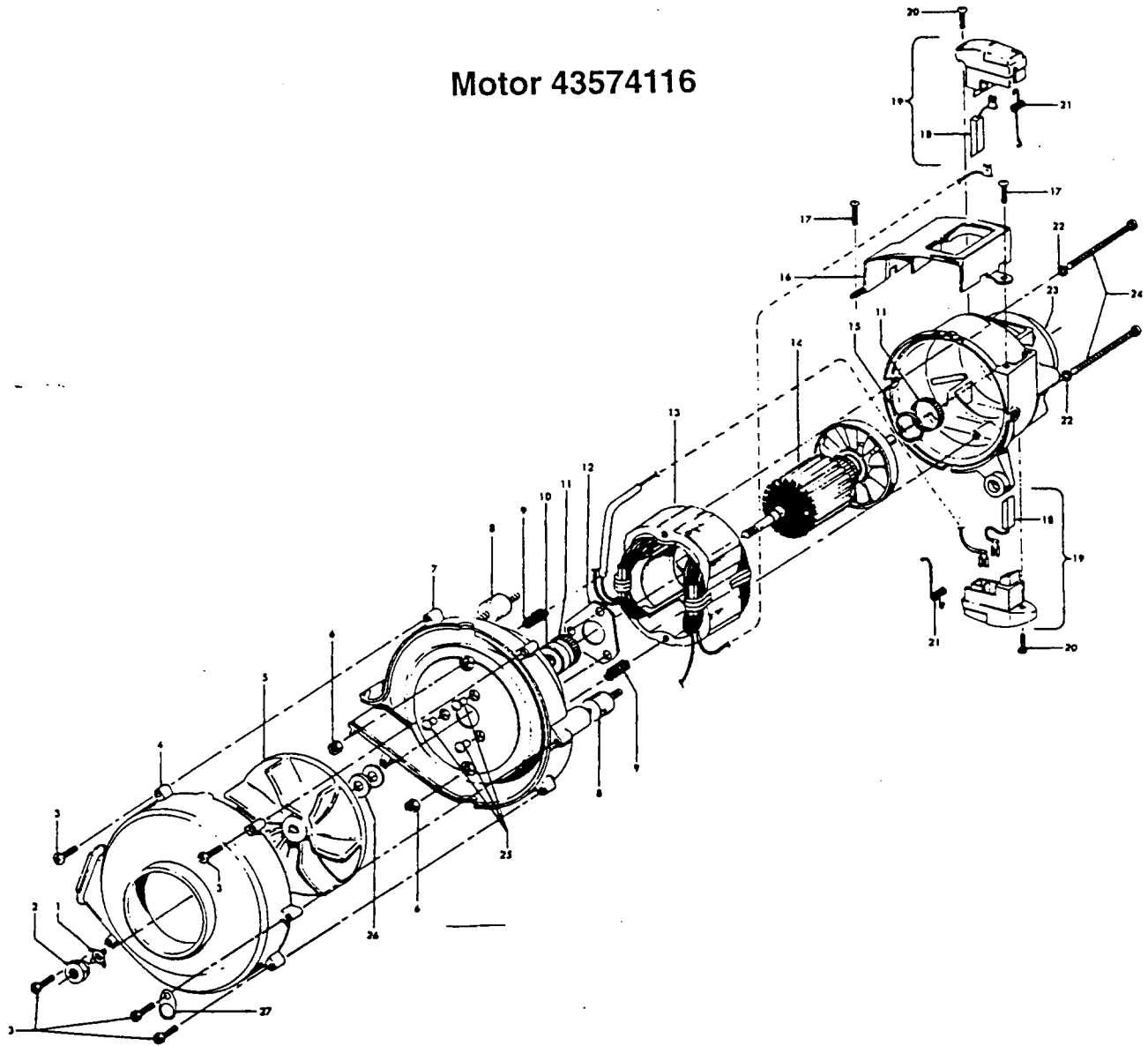

Ref. Part
No. No.

Description

	36128003	Lock Washer
2	33426001	Nut
3	21447072	* Screw
4	38736025	Fan Chamber Cove
5	38755012	Fan
6	21641557	* Nut
7	43588018	Fan Chamber
8	32724015	Sandwich Mount
9	12854	Spring
10	24152807	Bearing
11	24198001	* Star Ring
12	12025	* Retainer
13	45311056	Field Coil
14	44765184	Armature

Ref. Part
No. No.

Description

15	21345115	Washer
16	37257086	Air Intake Duct
17	21447041	* Screw
18	47315010	Carbon Brush
19	47318008	Brush Carrier Assm.
20	21479302	* Screw
21	38353004	Spring
22	21338006	* Lock Washer
23	37191090	Motor Housing
24	21563061	Screw
25	12503 EF	* Rivet
26	166563	* Washer
27	45517	* Lead Wire Holder