

EUREKA CANISTERS

6900 Series

Models: 6984A

HOME CLEANING SYSTEM

- 1.....E-548883.....Cord winder button
- 2.....E-60361.....Rear catch lever
- 3.....E-60637.....Catch lever spring
- 4.....E-616972.....Screw, 10 pk
- 5.....E-617123.....Cover
- 6.....E-61693.....Cord reel w/cord
- 7.....E-54985.....Power cord
- 8.....E-60541.....Motor filter
- 9.....E-60476.....Filter flap
- 10.....E-60286A.....HEPA filter
- 11.....E-60578.....Motor cover seal
- 12.....E-549391.....Hose (170mm)
- 13.....E-54893.....Bag indicator
- 14.....E-54914.....hose (185mm)
- 15.....E-60653.....Suspension block
- 16.....E-60605.....Gasket
- 17.....E-606481.....Cord guide
- 18.....E-548951.....Rear wheel
- 19.....E-616972.....Screw, 10 pk
- 20.....E-61695.....Front caster
- 21.....E-617083.....Tool pack cover
- 22.....E-549445.....Display
- 23.....E-548893.....Switch button
- 24.....E-606511.....Catch lever
- 25.....E-54894.....Shaft
- 26.....E-548865.....Bag cover lid
- 27.....E-606381.....Sleeve
- 28.....E-60605.....Gasket
- 29.....E-54892.....Bag support spring
- 30.....E-54890.....Bag support
- 31.....E-606061.....Power outlet
- 32.....E-61709.....Upper shell
- 33.....E-61694.....Motor block
- 34.....E-61698.....Thermostat
- 35.....E-606501.....Motor assembly
- 36.....E-606341.....Sealing ring support
- 37.....E-606471.....Sealing ring
- 38.....E-54973.....Spring
- 39.....E-616971.....Screw, 10 pk
- 40.....E-617061.....Circuit board
- 41.....E-60635.....Washer
- 42.....E-60632.....Flap plate
- 43.....E-60608.....Flap seal
- 44.....E-61710.....Lower shell
- 45.....E-606521.....Handle

Not Illustrated

- E-617032.....Wire
- E-61704.....Sound foam

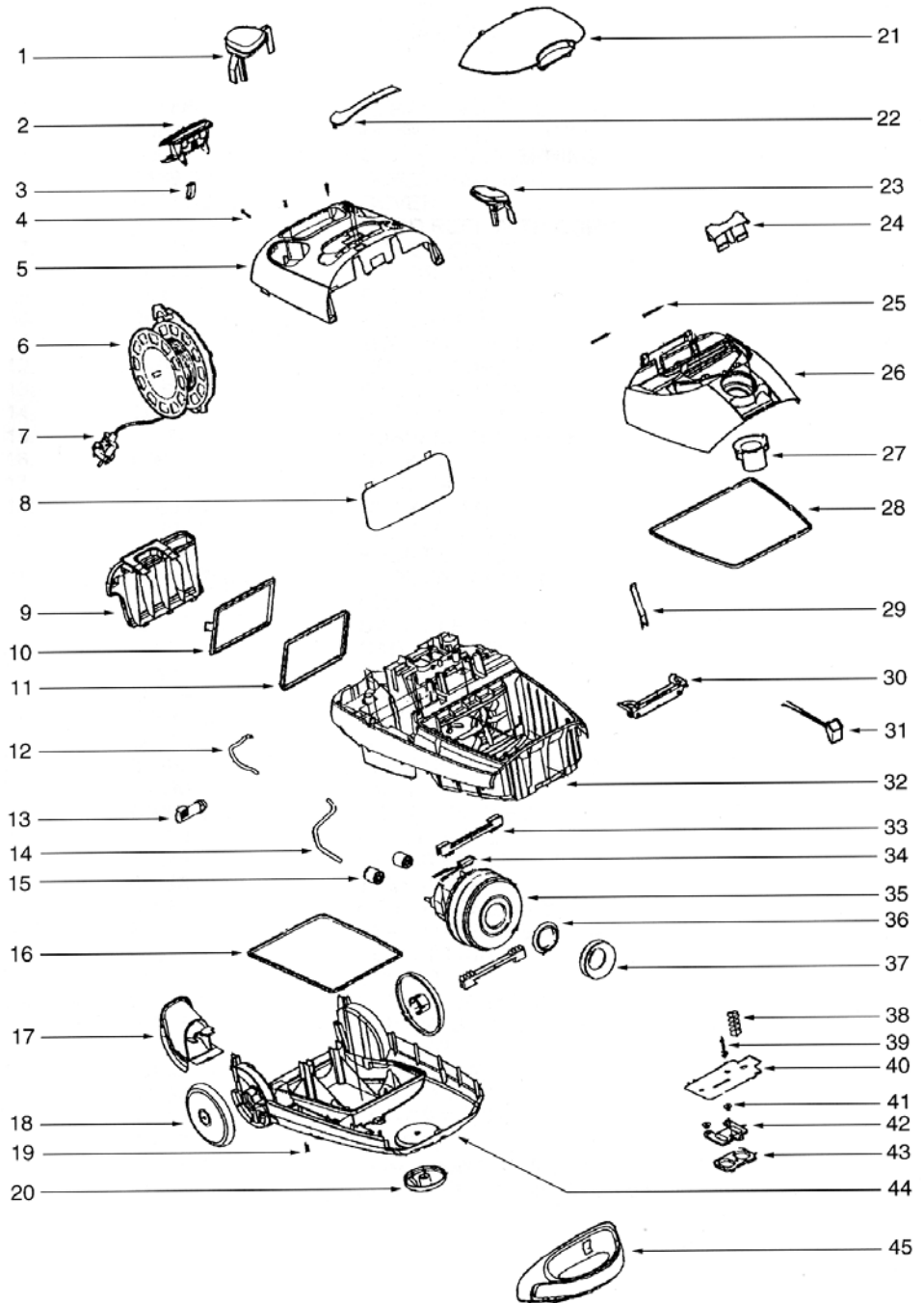

PHONE: 1-800-822-7467

FAX: 847-647-0534

E-MAIL: sales@hescoinc.com

WEB: hescoinc.com

EUREKA CANISTERS

6900 Series

Models: 6984A

HOME CLEANING SYSTEM

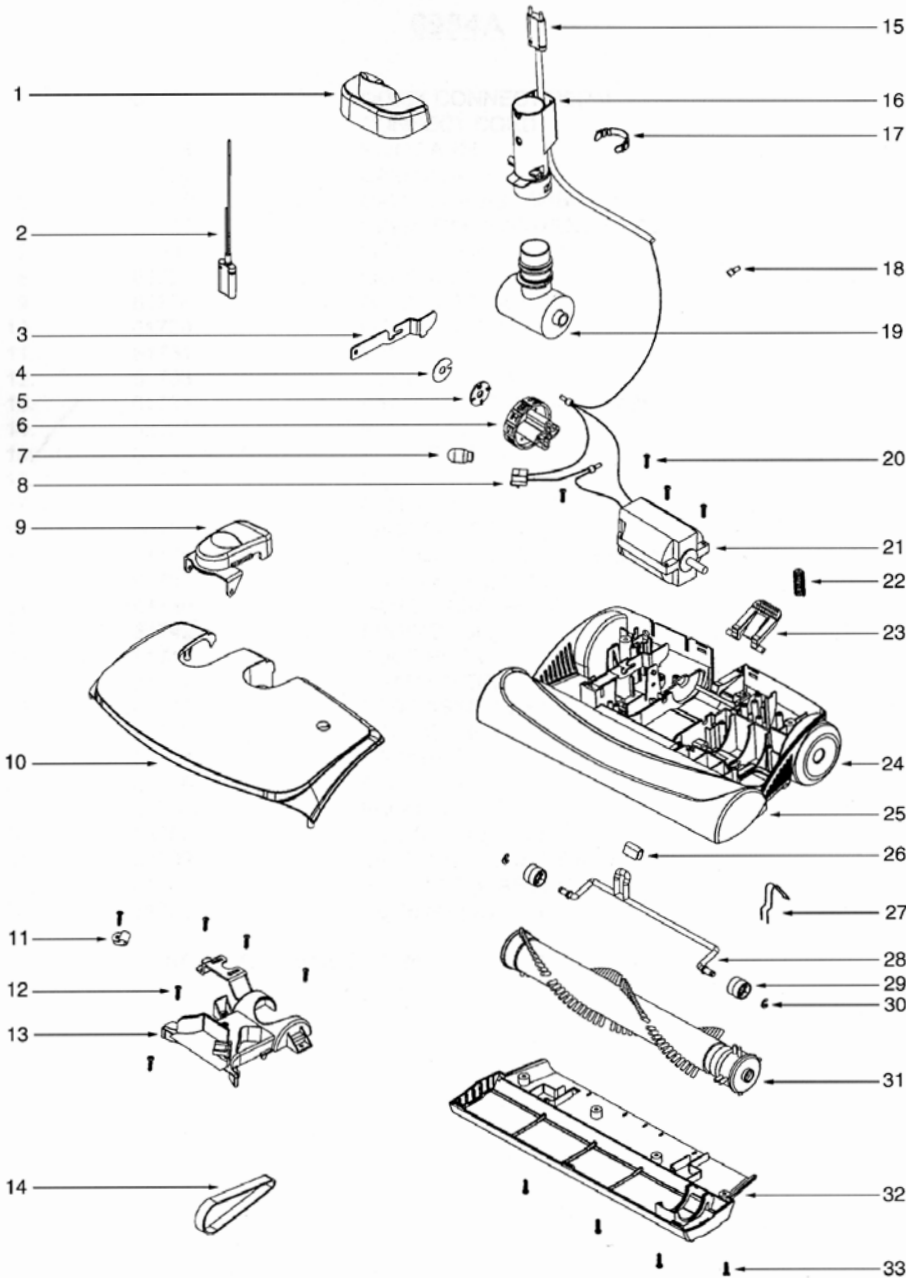

- 1..... E-61721.....Quick connect pedal
- 2..... E-61722.....Connect cord
- 3..... E-61723.....Wire arm
- 4..... E-61724.....Cam disk
- 5..... E-61725.....Cam lock assembly
- 6..... E-61726.....Height adjustment knob
- 7..... E-61682.....Light bulb
- 8..... E-61727.....Light socket
- 9..... E-61728.....Pedal Assembly
- 10..... E-61730.....Hood assembly
- 11..... E-61731.....clip
- 12..... E-61733.....Screw, 10 pk
- 13..... E-61734.....Air duct cover assembly
- 14..... E-52201B.....Belt, 2 pk
- 15..... E-61735.....Power cord
- 16..... E-61736.....Coupling
- 17..... E-61737.....C-clamp
- 18..... E-601921.....Wire splice, 5 pk
- 19..... E-61738.....Handle socket assembly
- 20..... E-61733.....Screw, 10 pk
- 21..... E-61740.....Motor assembly
- 22..... E-61742.....Spring, 5 pk
- 23..... E-61743.....Foot pedal
- 24..... E-61744.....Rear wheel
- 25..... E-61746.....Base assembly
- 26..... E-61747.....Cam bearing
- 27..... E-61748.....Spring
- 28..... E-61749.....Front axle
- 29..... E-61750.....Front wheel
- 30..... E-61752.....E-ring, 10 pk
- 31..... E-61699.....Brush roll assembly
- 32..... E-61753.....Sole plate assembly
- 33..... E-61733.....Screw, 10 pk

EUREKA CANISTERS

6900 Series

Models: 6984A

HOME CLEANING SYSTEM

- 1..... E-54905.....Crevice tool
- 2..... E-54904.....Upholstery tool
- 3..... E-39422B-3.....Upper wand
- 4..... E-39422B-3.....Lower wand
- 5..... E-532571.....Screw, 10 pk
- 6..... E-38948336N.....control knob
- 7..... E-608523.....Hose handle assembly, complete*
- 8..... E-391346.....Floor Nozzle
- 9..... E-54903.....Dusting brush
- 10..... E-60816.....Floor & wall brush
- 11..... E-59949.....Mini turbo
- 12..... E-60284A.....Disposable bag(style ex), 3 pk
- 14..... E-607822.....Hose assembly, complete**
- 15..... E-277303.....Cord assembly

* Includes item 5

** Includes items 5, 6, 7, & 15

